

JTVG Lever Block



Lifting



Lowering



Fastening



Pulling



Unique Anti-release System



Patented Fused Brake

Introduction

- Patented Fused Brake Design-Proven durability that increases safety.
- Weston Style Dual Pawl Brake System- Double pawl design increases safety.
- Unique hand wheel & knob design-No preload required.
- Corrosive resistant zinc plated grade 100 load chain.
- Alloy Steel Hook- Industrial rated hooks rotate 360 degrees for easy rigging.
- Cast Steel Safety Latches- Increased durability with heavy duty safety latches secured with Allen screws and locknuts.
- Caged Needle Bearing Design- Increases efficiency and promotes smooth operation extending the work life of the hoist.
- Compact Design- Smaller body and lightweight design for low headroom applications and use in confined areas.

Optional Features

- Caged roller bearings on load sprocket
- Zinc plated load chain
- Cast latches
- Shipyard hook 1.6t & 3.2t

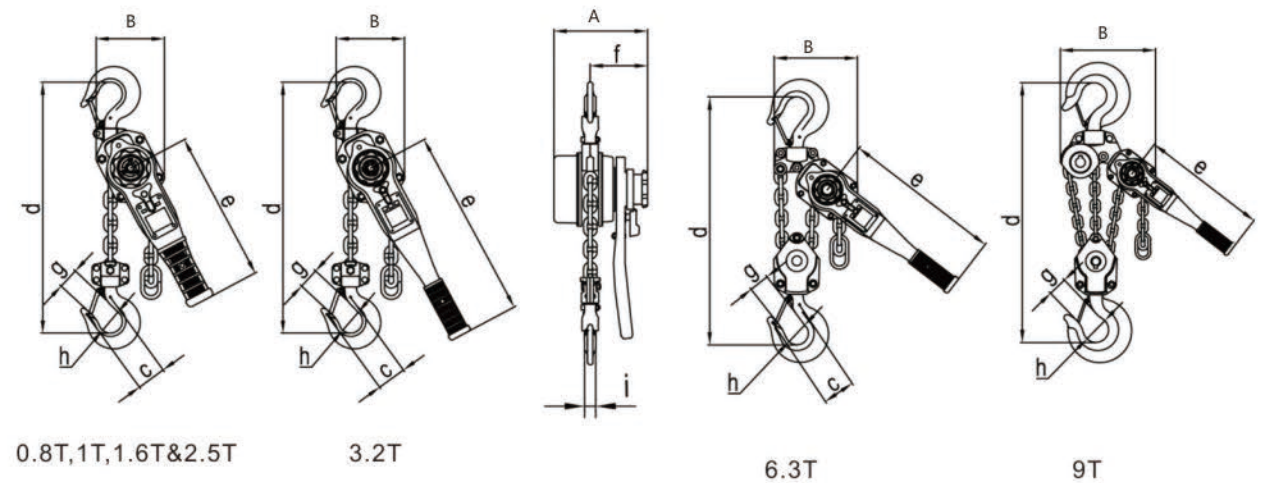

Specifications

Model	Capacity (T)	Standard lift (m)	Running test (T)	No. of falls of load chain	Load chain diameter(mm)	Dimension(mm)									Net weight (kg)
						A	B	C	D	E	F	G	H	I	
JTVG 0.8T	0.8	1.5	1.2	1	5.6	146	119	41.5	280	245	96	26.5	35.5	14	5.7
JTVG 1.0T	1	1.5	1.5	1	5.6	146	119	49.4	300	245	96	31.5	42.5	15	5.9
JTVG 1.6T	1.6	1.5	2.4	1	7.1	164	126	52	335	265	100	35.5	42.5	19	8
JTVG 2.5T	2.5	1.5	3.75	1	8.8	179	150	58.6	375	265	103	41	47	21	11.2
JTVG 3.2T	3.2	1.5	4.8	1	10	196	159	61.9	395	415	114	43	50	24.5	13.6
JTVG 6.3T	6.3	1.5	9.45	2	10	196	218	84.3	540	415	114	53	60	34	26
JTVG 9.0T	9	1.5	13.5	3	10	196	298	-	680	415	114	64	85	40	40