

JTVD Chain Block



Moving Products



Uprooting Trees



Installing Underwater



Laying Conduits And Pipelines

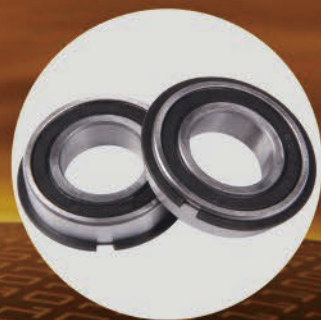

Sealed Roller Bearings



Casting Guide Wheel



Unique Curled Edge

Introduction

- All Steel Construction-Impact resistant covers that provide durability and protection.
- Double pawl and double guide rollers enhance performance,safety and reliability.
- Unique curling design-This feature enables the hand chain to successfully feed directly into the wheel sprocket from many directions and angles.
- Grade 80 Load Chain-Grade 80 black oxide coated load chain for durability.
- Forged alloy Steel Hooks-Industrial rated hooks rotate 360 degrees for easy rigging. Hooks slowly stretch to indicate an overload situation increasing jobsite safety.
- Sealed roller bearings-Greatly improving performance and serve life of the product.
- Certification-Load tested to 150% of capacity with certificate.

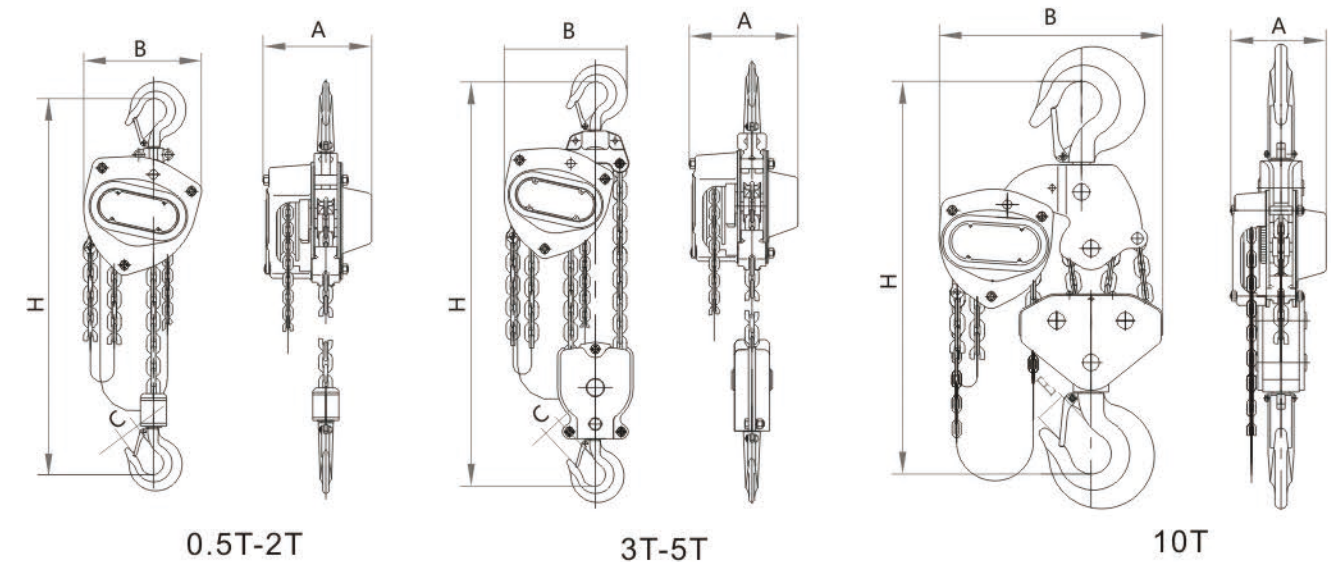

Specifications

Model	Capacity (T)	Standard Lift(m)	Running test (T)	Effort required to lift max load (N)	No.of falls of load chain	Load chain diameter(mm)	Dimension(mm)				Net weight (kg)	Packing (L*W*H)(cm)
							A	B	C	H		
JTVD-0.5T	0.5	2.5	0.75	240	1	5	132	148	28	345	11	24*19*18
JTVD-1T	1	2.5	1.5	250	1	6	151	172	32	376	12.5	28*21*21
JTVD-1.5T	1.5	2.5	2.25	265	1	7.1	173	196	36	442	17.8	34*26*20
JTVD-2T	2	3	3	335	1	8	175	210	36	470	19.5	34*26*20
JTVD-3T	3	3	4.5	363	1	10	176	230	46	565	29	34*26*20
JTVD-5T	5	3	7.5	360	2	9	189	280	46	688	41.3	41*32*24
JTVD-10T	10	3	15	380	4	9	189	463	57	765	78.5	48*42*18.5