

国家高新技术企业

维多利科技（江苏）有限公司
JT(JIANGSU)TECHNOLOGY CO.,LTD



MESSAGES FROM JENTAN

With more than 30 years of experience, Jentan Group has always adhered to the concept of quality products, efficient production capacity, professional team and excellent service, and is committed to becoming the global best intelligent stage hoist supplier!



Company Profile

JENTAN Group is an enterprise specializing in the production of hoisting hoists. The company's headquarters is located in Linping New City, Hangzhou with the beautiful West Lake. It has two production bases in Huai'an, the capital of the canal, and Xiong'an, Hebei. The factory covers an area of 4.6 acres. The company was founded in 1988, the product has passed the National Lifting and Transportation Quality Supervision and Inspection Center issued a production license, has more than 60 inventions and practical patents, the company has passed the ISO 9001 quality management system certification, the European Rheinland GS certification, CE certification, American UL certification, Canadian CUL certification, Australian standard certification and China Electric Power Research Institute testing certification. The company produces and sells manual hoists, electric hoists, slings, and other lifting equipment under the "Jentan" and "Hugo" brands. For more than 30 years, the products have always maintained high quality and have been recognized by customers. They have an annual output of various types of lifting equipment. There are more than 500,000 hoists, and the products are exported to more than 100 countries and regions. The product quality liability insurance is underwritten by the PICC.

Our development vision is to become the world's most high-quality lifting hoist supplier. The company has always focused on technology research and development, and has cultivated and built a lifting hoist research and development center composed of mechanical design, process equipment, intelligent programming and electrical engineers. Engaged in the research of lifting hoist and the development of new products in line with the future development trend. Product quality is the foundation of an enterprise. The company has a product quality technical test center, a domestic leading metallographic physical and chemical laboratory, a 100-ton universal material testing machine, a 300-ton horizontal tensile machine, a fatigue testing machine, a salt spray testing machine, 50 ton electric hoist comprehensive testing platform and other testing equipment.

Looking forward to the future, we are full of self-confidence and strength to create products with higher performance and higher quality-price ratio for customers. Customer satisfaction is the direction of our efforts. Warmly welcome domestic and foreign customers to come to discuss cooperation and create a win-win road.

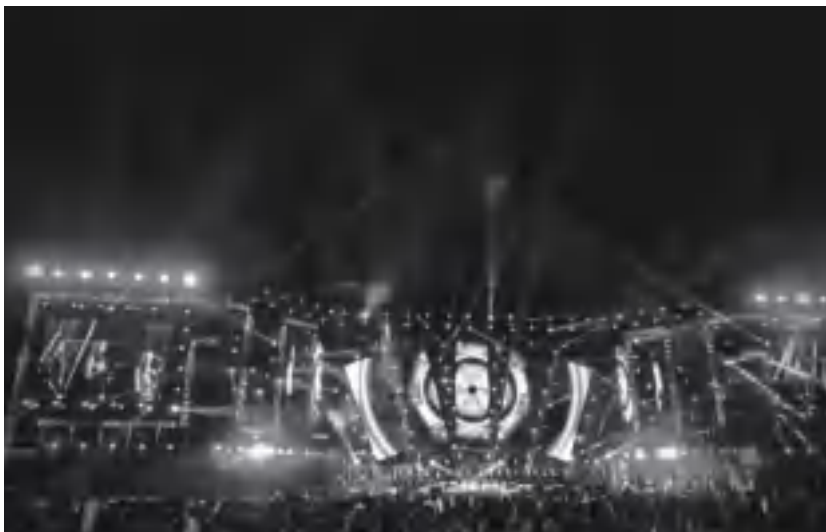

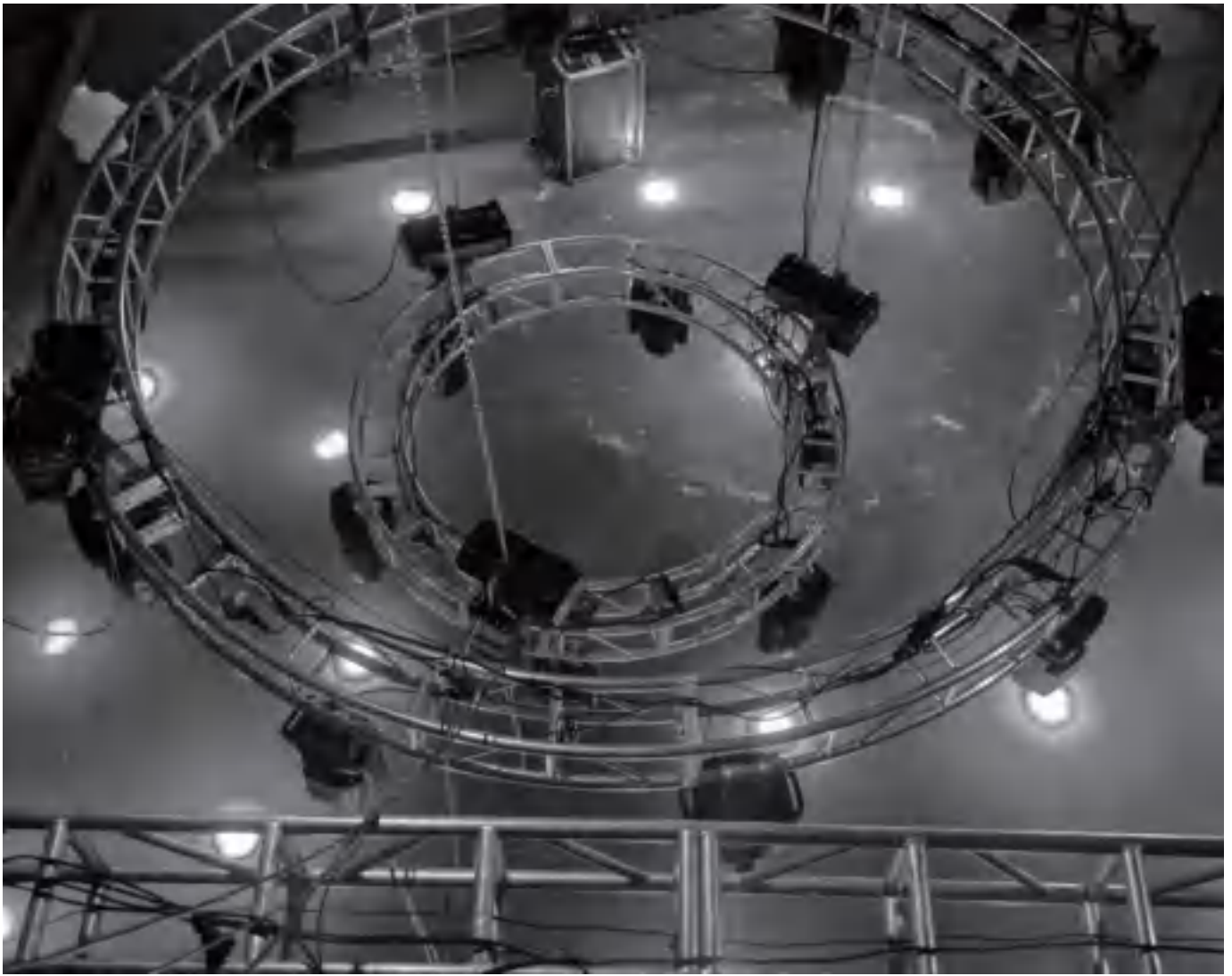

JENTAN-ELECTRIC CHAIN HOIST

With UL and CUL Certified



PRODUCT FEATURES

- Capacity from 500kg~3000kg;
- Both directions hanging is optional;
- Direct or indirect control;
- High strength nylon bag;
- 1 PC DC brake;
- 5 times safety factor;
- Mechanical safety clutch;
- High strength G80 load chain;
- Dual brakes and adjustable 2 points
limit switch and encoder are optional



Protection

The body reaches the IP65 protection level, which can effectively prevent dust and water.

Safety

The strength of the hoist can reach 8 times safety factor, and breaking force of the load chain can reach 8 times.

Work level

The product reaches M4 level to adapt to higher intensity applications.

Novel body structure

With high-strength all-aluminum alloy body, beautiful appearance, compact body, small size, light weight, strong and durable shell.

Product design

The design is more reasonable, which can quickly repair the clutch, motor, circuit control board and brake system, and speed up maintenance efficiency.

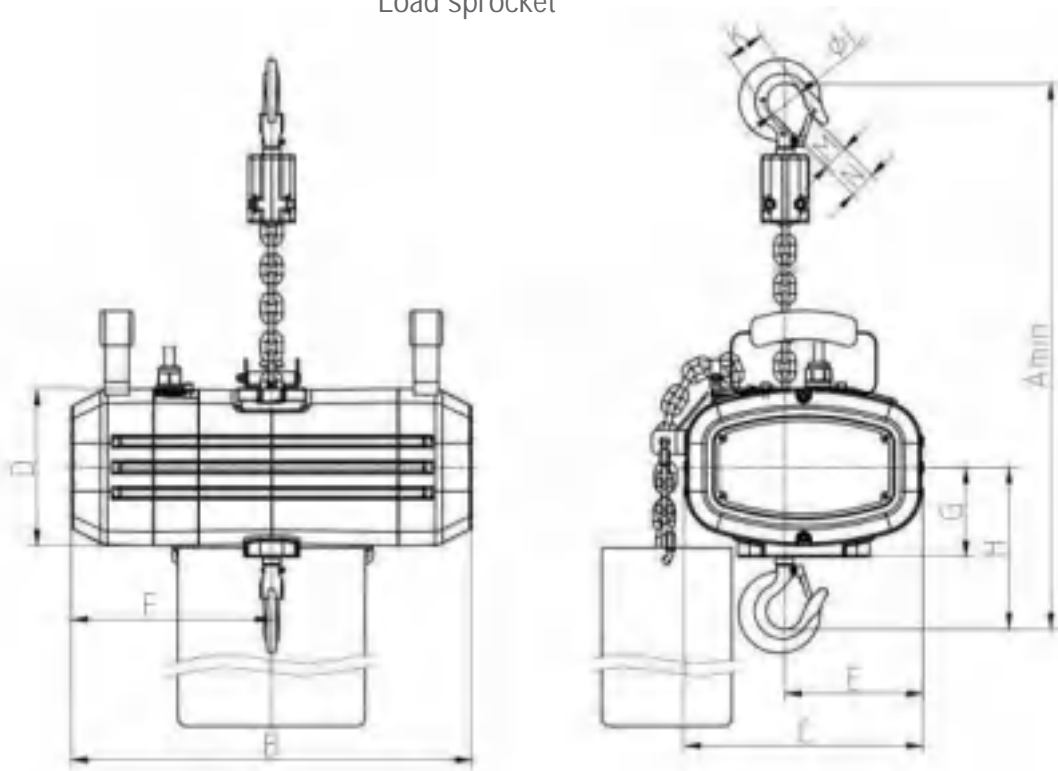
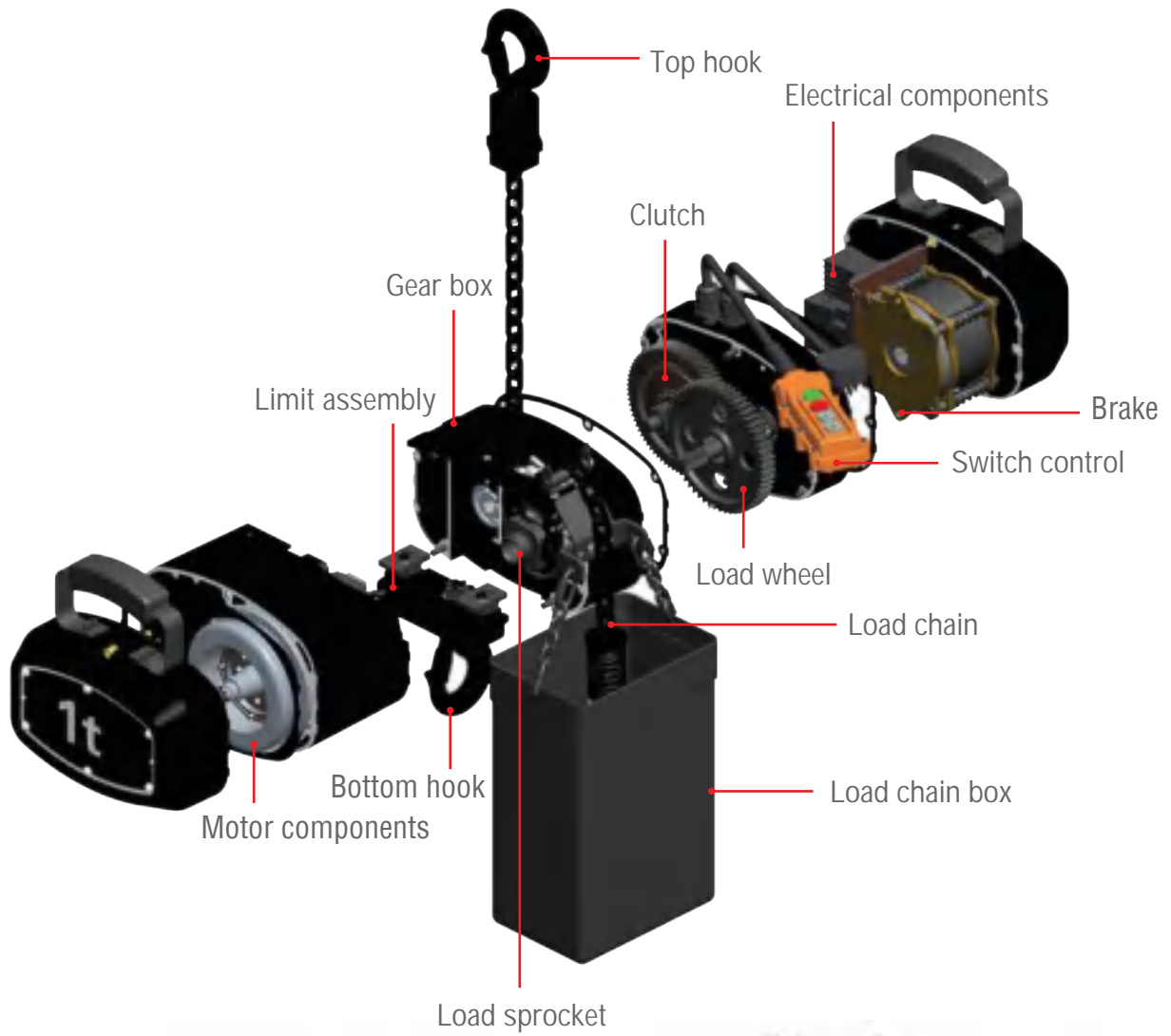

Technical Parameters

Model No.	JTDG1F1-0.25A	JTDG1F1-0.5A	JTDG1E1-1B	JTDG1B2-2B
W.L.L. (T)	0.25	0.5	1	2
Lifting Speed (m/min)	8	4	4	3.4
Chain falls	1	1	1	2
Motor Power (kw)	0.4	0.9	1.6	1.6
Load Duration (%)	40	40	40	40
Load Chain (d _{xp})	5×15	6.3×19	8×24	8×24
N.W. (kg)	30	35	56	58
Extra weight per lift (%)	0.56	0.88	1.42	2.84

Note: 500kg and 1000kg can be upgraded to 8m/min

Dimensions(mm)

Model No.	JTDG1F1-0.25A	JTDG1F1-0.5A	JTDG1E1-1B	JTDG1B2-2B	
W.L.L. (T)	0.25	0.5	1	2	
Dimensions (mm)	A	439	455	545	545
	B	428	428	493	493
	C	229	229	294	294
	D	165	165	193	193
	E	124	124	171	171
	F	235	235	247	247
	G	92	92	114	114
	H	168	168	197	197
	L	35	40	45	45
	K	41	45	49	49
	M	23	27	31	31
N	27	30	36	36	

Note: 1. Common spec: 3 phases, 380V, 50Hz, other specs can be customized.

2. Above specs can be upgraded by the manufacturer.

PROTECTION GRADE IP65



Waterproof



Dust-proof





Hook

The upper and lower hooks are forged from high-quality alloy steel and are malleable after heat treatment. Even if the damage is caused by overload, the hooks will only be deformed without brittle fracture. The hooks can 360° rotate, more convenient to use.



Lifting chain

High-strength galvanized chain, high safety factor, long service life, and can effectively prevent corrosion; in addition, there are black chains are optional.



Guide sprocket

Adopts 5 chain socket guide sprocket, which increases at least 25% matching degree compared with the traditional 4 chain socket guide sprocket, reduces the wear of the chain, and makes the lifting process more stable.

Gear

Adopts high-precision helical gear, the whole machine has lower operating noise, as low as 60 decibels.



Overload protection

With overload safety clutch, beyond the fixed torque, the hoist cannot be lifted to prevent safety hazards caused by overload.



Brake system

Adopt QPQ surface coating anti-corrosion double brake system, the safety factor is doubled

8 Times Safety Factor



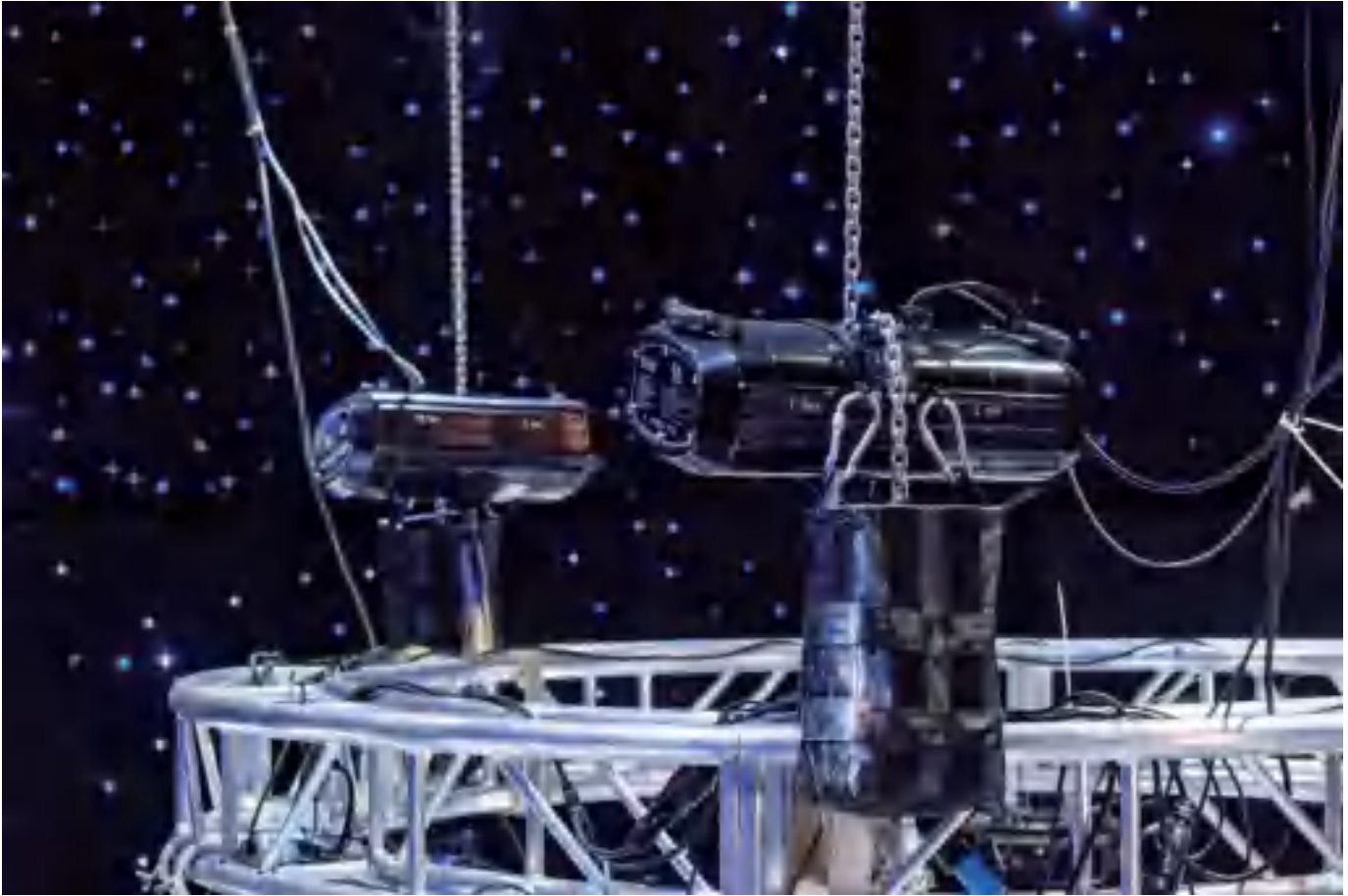

Features of CNC hoist

1. The design meets the requirements of the international entertainment industry, is designed according to the JB/T5317-2016 electric chain hoist industry standard, and meets the IGVWSQ P2 standard and all current standard requirements.
2. The closed-loop control of position, speed and torque is realized, and the accuracy of basic repetitive motion to complex 2D and 3D motion can be within 0.1mm.
3. The high-speed performance is good and the control response is timely and rapid. The JTDG series intelligent CNC hoist can reach a speed of 25m/min, the dynamic response time of acceleration and deceleration is short, and the corresponding action can be made within tens of milliseconds.
4. JTDG series intelligent numerical control hoist has strong anti-overload capability and can bear a load of three times a thousand rated torque, which is especially suitable for occasions with instantaneous load fluctuations and requirements for fast starting.
5. JTDG series intelligent CNC hoist runs smoothly at low speed, suitable for occasions with corresponding high-speed requirements.
6. Re-designed the fuselage and mechanism, and seamlessly embed the load-bearing detection application solution that has not been well resolved into the fuselage, making this function built-in.

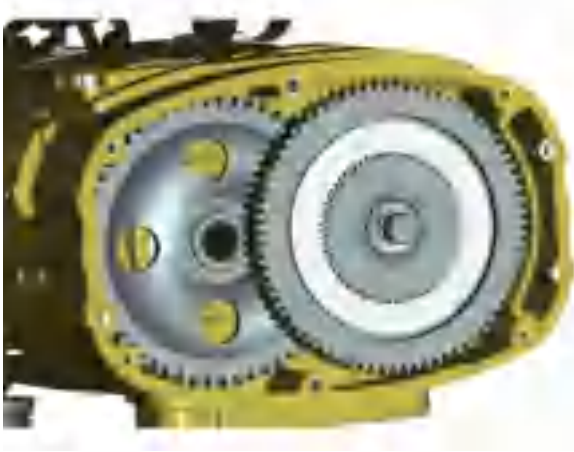

Gear system

It is designed and manufactured according to German standard. The traditional multi-stage gear system is matched with a sealed gear box with a spiral tooth shape. It is free of oil for life and prevents oil dripping during performances.

Intelligent

The embedded intelligent programming system enables multiple products to achieve the overall coordination of speed and action, thereby meeting the overall lifting requirements, coordinating the up and down running speed, free adjustment, and the encoder promotes synchronization optimization. On the original basis, higher accuracy, PLC programming technology, to meet the preset of various actions, more flexible, and more beautiful stage effects.



Limit switch

Double limit switch, which can automatically stop at a predetermined position when the hoist is rising and falling to prevent overtravel.



Small shaft sleeve type incremental encoder

To achieve a greater degree of freedom and multi-flexibility connection, metal die-cast housing, with good resistance to mechanical damage, which can withstand higher axial and radial loads, advanced signal processing technology Combined with a wealth of electrical output forms, it can meet the application needs of different upper computers.

M5 GRADE

Higher strengthHigher strength

NOVEL STRUCTURE

High-strength all-aluminum alloy body, beautiful appearance, compact body, small size, light weight, strong and durable cover.

REASON ABLE

Can quickly repair the clutch, motor, circuit control board and brake system, and speed up maintenance efficiency.





Frequency converter

Inverter has three control modes of position, torque, and speed, open loop and closed loop applications, and can drive asynchronous motors, synchronous motors, and synchronous reluctance motors, making the hoist more stable during lifting and lowering.



Controller

- The controller is generally divided into 4 channels, 8 channels, 12 channels, 24 channels, etc. According to the model, the ABS box type three-dimensional control box is used.
- The controllers are respectively suitable for low-voltage control and direct control motors of electric hoists. Single-phase electric hoist controllers can be provided upon request.
- Can be controlled by panel or handle.
- It can be controlled by a single unit or in a group. Each channel has an up/down selection switch, and the "Start" button can activate all pre-selected ways.
- With leakage protection device and phase conversion function.
- Emergency brake switch.



On-screen intelligent console

Through the on-screen intelligent console, multiple stage hoists can be linked, with the same synchronization, can do more actions, have higher security and easier to use.

维多利[®]

维多利科技（江苏）有限公司
JT(JIANGSU)TECHNOLOGY CO.,LTD

杭州维多利机械有限公司
HANGZHOU JENTAN MACHINERY CO.,LTD

地址：江苏省淮安市工业园区发展东道8号
地址：浙江省杭州市余杭区世纪大道1号美亚大厦21层
电话：0571-86258682 0571-86258685
 0571-89702588 0571-89701888
传真：0571-86186028 0571-89702016
官网：www.jentanhoist.com
邮箱：info@jentanhoist.com

